	Client:	Hanjin HI		Client ref.:	SHT-07071
	Proj ref:	168/169/170/171		IMO AB ref.:	4068538
	Item no/ref:	2			
	Service:	DO TRANSFER PUMP			
	No of units:	1			Henrik Wikström
PUMP	Make/Model	IMO AB		ACG 070K7 NVBP	
	Size & Rating	0,251 dm3/rev		16 bar	
	Ports	DIN-flanges		In: 100 ND16 Out: 100 ND16	
DRIVER	Make/Model	BC		WU-DA 132SF-D-4	
	Size & Rating	IEC 132	440V/60Hz	6,3 kW/1760 rpm	
	Prot & mounting	F/IP55	IC41	IM3001/B5	
UNIT	Type	Single unit, vert. shaft			
	Incl. accessories	Connecting frame Angle bracket Shaft coupling			
DATA	Required flow	20	20	m³/h	
	Delivered flow	24,3	25,8	m³/h	
	@ Viscosity	25,8	260	cSt	
	@ Oper. speed	1777	1765	rpm	
	Absorbed power	3,6	5,5	kW	
	Outlet pressure	3,0	3,0	bar	
	Inlet pressure	-0,6	-0,6	bar Min. -0,8 @ 25,8 cSt	
	Inlet temp	32	32	°C	
NOTES					
Spare parts <i>(for two years of operation)</i>		Accessories		Litterature	
		1 GAUGE PANEL 5/6 BAR 2 ROOT VALVE/COCK 1 Cable gland M25 10-19 mm 1 Protection roof 1 1 set bite type Con ACG		Installation manual Service manual Product description	
Driver data				Documents	
Nom. current 11,3 A Start. current 79,1 A DOL Efficiency 86% cos (fi) 0,82 Main cable 1xM25*1.5 Aux. cable M20*1.5 Wind'g heating Earthing Terminal box & cooling rib				Pump section dwg A-ACG-085 Dimension dwg no U-ACG-440 Pump Parts List P-ACG-089 Unit Part list Spare parts list S-ACG-225 Perform. curve Driver dwg no X-MOT-782A Gauge panel E-MAN-071A	
Material		Weight		Miscellaneous info	
Pump casing #Värdefel! Motor casing Aluminium Pump rotor #Värdefel! Idler #Värdefel! Shaft seal #Värdefel!		Pump 54 kg Driver 45 kg Accessories 21 kg Tot. unit 120 kg		Pressure test 7 bar Valve setting 4,5 bar Paint color pump Munsell 7.5 BG 7/2 Paint color motor Munsell 7.5 BG 7/2 Certificates GL	



Pump performance
ACG 070K7 NVBP

2

2005-01-24

Duty case No.		1	2
Speed	rpm	1777	1765
Viscosity	cSt	25.8	260
Inlet temp	°C	32.0	32.0

Calc'd flow [m³/h]

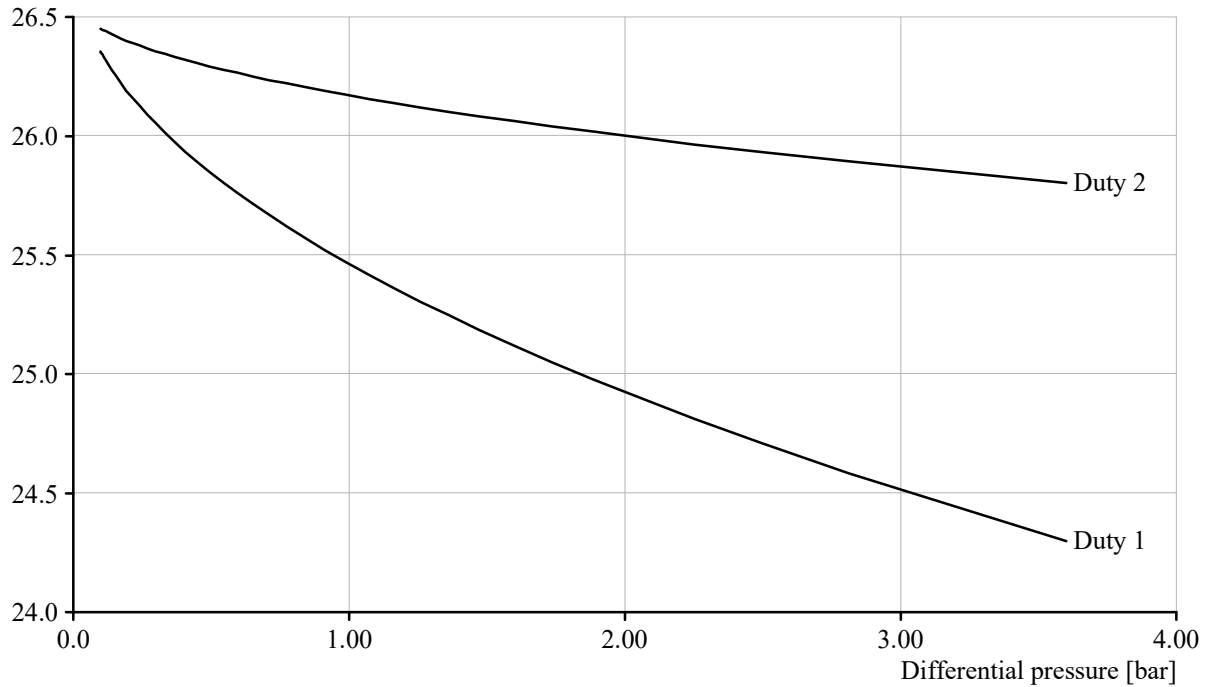

Power [kW]

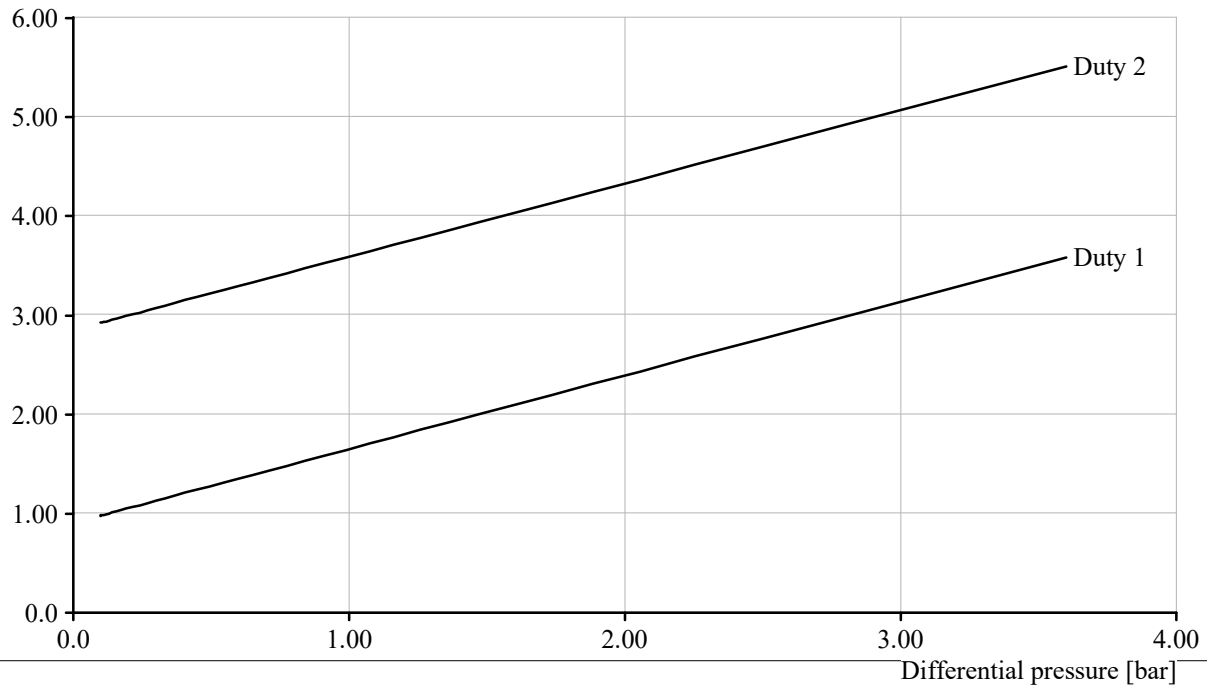



IMO AB
Stockholm
Sweden

IMO-Pump unit
ACG 070K7 NVBP
with motor
BH WU-DA 132SF-D-4

Drawing Type-No.

U-ACG-440

Sheet 1 of 1

Only to the extent expressly agreed by us this document may constitute a contractual obligation on our part.

This document and its contents are our exclusive property and must not be copied, reproduced, transmitted or communicated to any other party or used for purposes not expressly permitted by us.

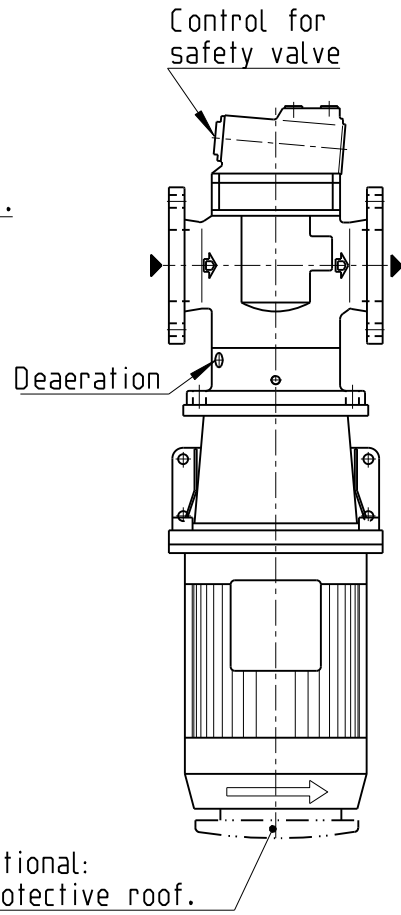
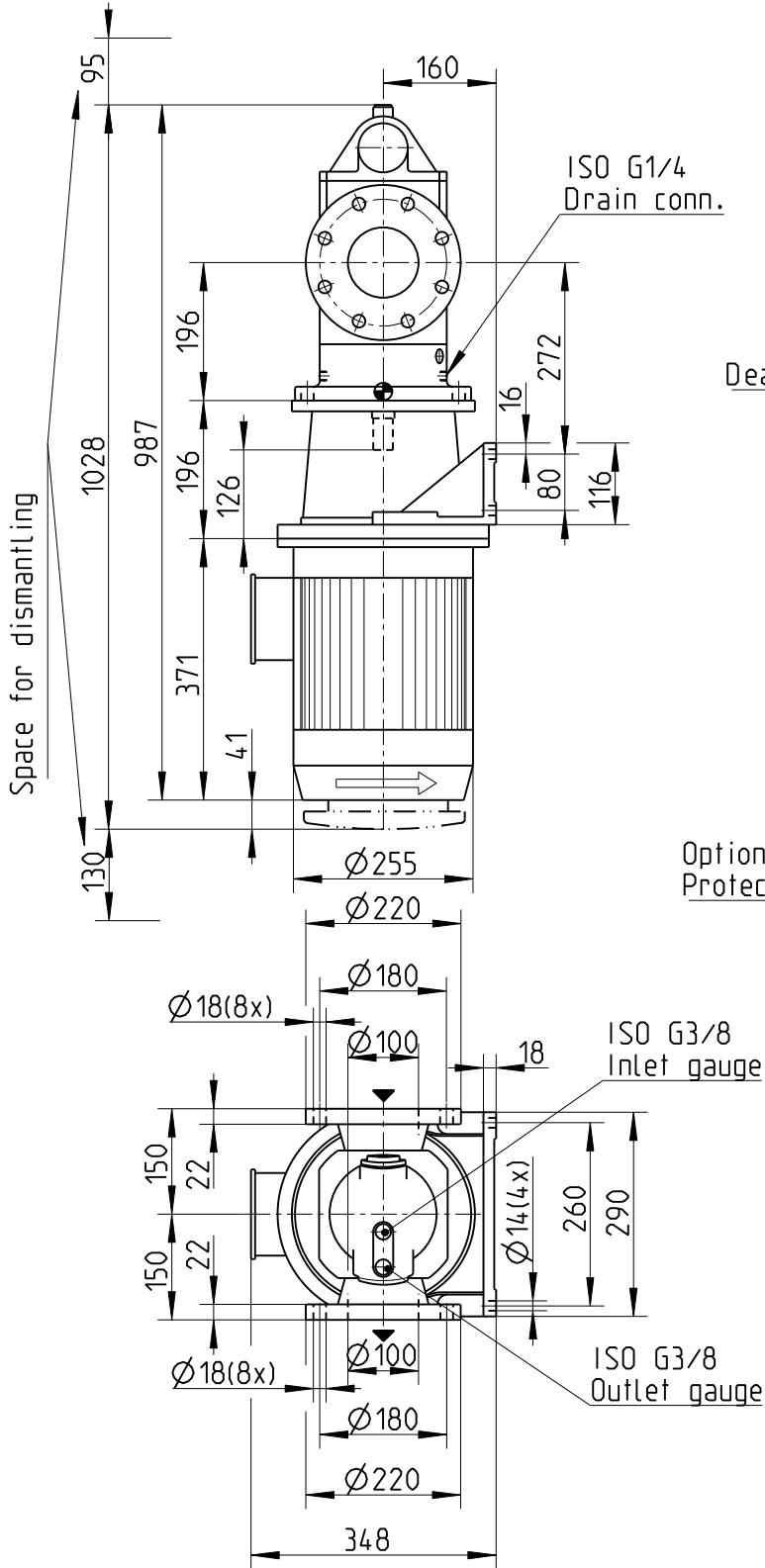

Dimensions in mm.

Weight approx. 120kg.

Counter flange acc.to
DIN2633/ND16.

First angle projection

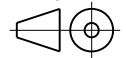

Original	2005-05-17 BS	Drawing Type-No.	Rev.
Rev.	Revision	Revised (Date/Sign) Appr.	U-ACG-440



IMO AB
Stockholm
Sweden

SECTIONAL DRAWING

ACG 070K7 NVBP

Drawing Type-No.

A-ACG-085

Sheet 1 of 1

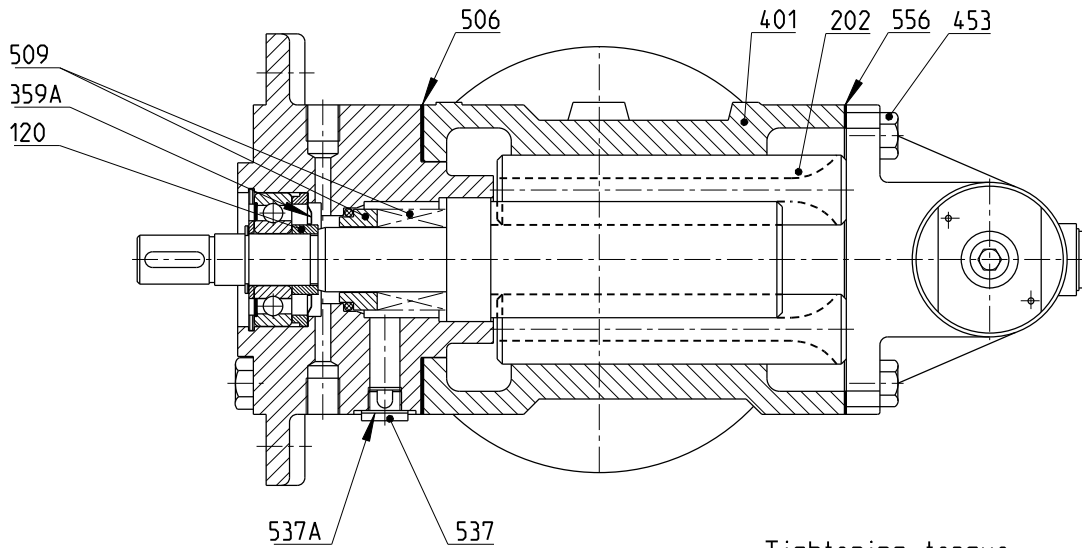
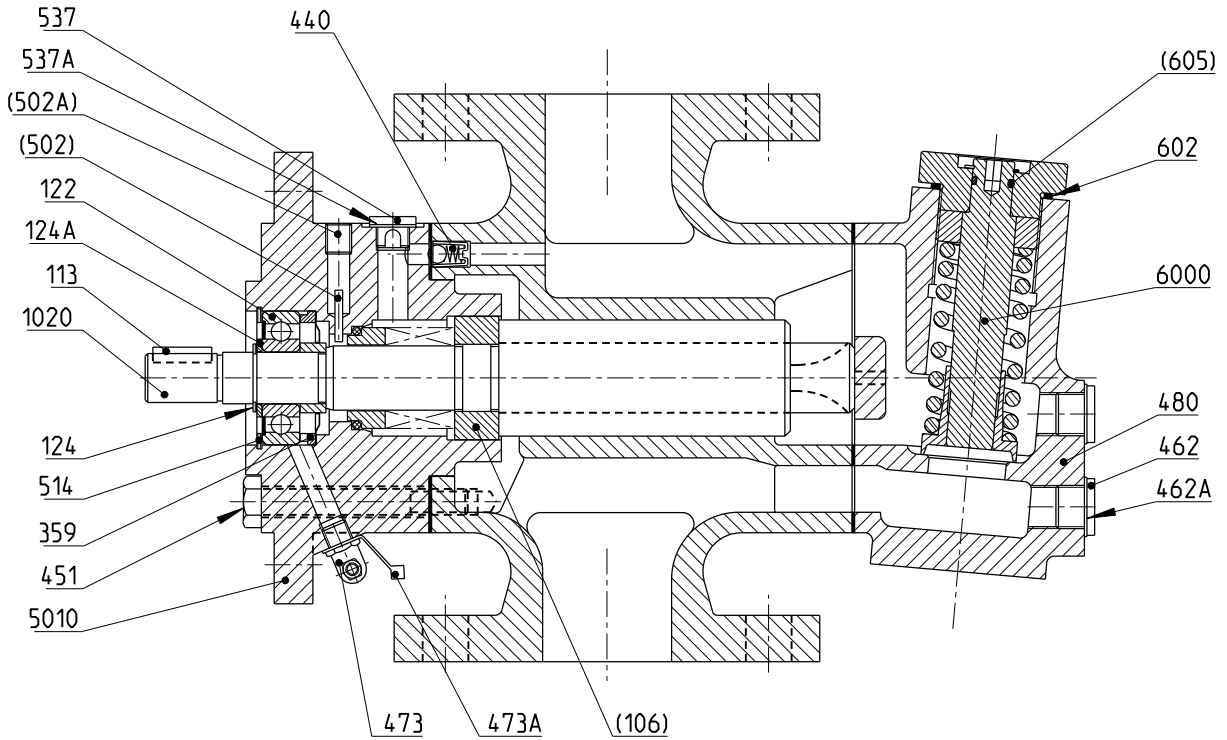

Tightening torque

POS.NO	Nm
451	81
453	81

First angle projection

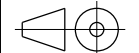

Only to the extent expressly agreed by us this document may constitute a contractual obligation on our part.

This document and its contents are our exclusive property and must not be copied, reproduced, transmitted or communicated to any other party or used for purposes not expressly permitted by us.

Original	03.01.21 LN	Drawing Type-No.	Rev.
Rev.	Revision	Revised (Date/Sign) Appr.	A-ACG-085



IMO AB
Stockholm
Sweden

PARTS LIST

ACG 070K7 NVBP

Drawing Type-No.

P-ACG-089

Sheet 1 of 1

Pos nr	Part Denomination	No	Material	Treatment/ Suppliers code	Specified standard	Equivalent standard JIS
1020	Compl.power rotor	1	Steel	Nitrocarb.	SS 2142	
(106)	Balancing piston	1	Steel		SS 2142	
113	Key	1	Steel			
120	Distance sleeve	1	Steel		SS 2142	
122	Ball bearing	1	Steel			
124	Retaining ring	1	Steel	Hardened		
124A	Support ring	1	Steel	Hardened		
202	Idler rotor	2	Cast iron	Nitrocarb.	SS 0125	FC25
359	Distance ring	1	Steel		SS 2172	
359A	Nilos ring	1	Steel			
401	Pump body	1	Nod.cast iron		SS 0722	
440	Return valve	1				
451	Screw	6	Steel	Class 8.8		
453	Screw	4	Steel	Class 8.8		
462	Plug	2	Steel			
462A	Washer	2	Aluminium		SS 4005	
473	Grease nipple	1	Steel			
473A	Protecting cup	1				
480	Valve housing	1	Nod.cast iron	Nitrocarb.	SS 0722	
5010	Compl.front.cover	1	Nod.cast iron		SS 0722	
(502)	Tenison pin	1	Steel			
(502A)	Screw	1	Steel			
506	Gasket	1	KlingerSil	C-4400		
509	Machanical seal	1			DIN24960 BMVGE	
514	Retaining ring	1	Steel	Hardened		
537	Deaeration plug	2	Steel			
537A	Washer	2	Aluminium		SS 4005	
556	Gasket	1	KlingerSil	C-4400		
602	Washer	1	Aluminium		SS 4005	
605	O-ring	1	Fluor rubber			
6000	Compl. valve	1				

SS= Swedish standard
JIS= Japan standard

Only to the extent expressly agreed by us this document may constitute a contractual obligation on our part.

This document and its contents are our exclusive property and must not be copied, reproduced, transmitted or communicated to any other party or used for purposes not expressly permitted by us.

	Original	03.01.21 LN	Drawing Type-No.	Rev.
Rev.	Revision	Revised (Date/Sign)	Appr.	P-ACG-089



IMO AB
Stockholm
Sweden

EL.MOTOR
BROOK CROMPTON
WU-DA 132SF-D-4

Drawing Type-No.

X-MOT-782A

Sheet 1 of 1

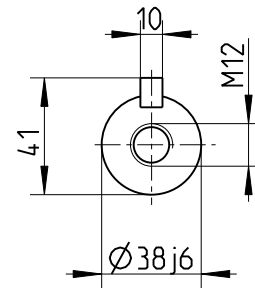
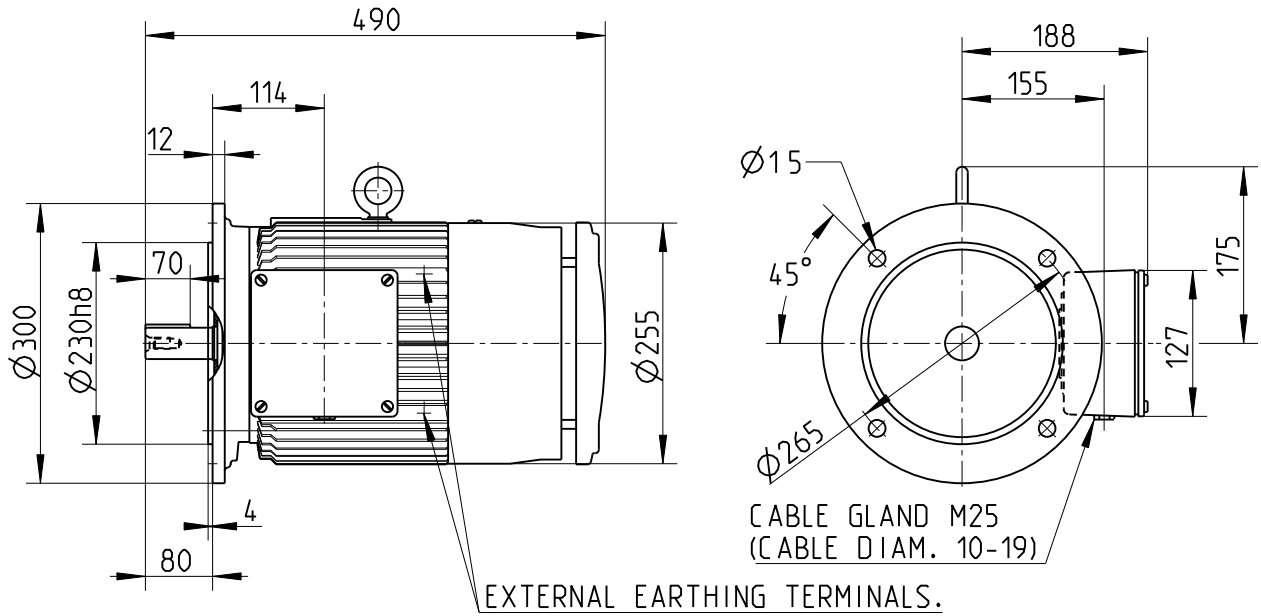

Rated power:	6,3kW
Speed:	1760rpm
Voltage:	440V
Frequency:	60Hz
Starting current:	79,1A
Rated current:	11,3A
Weight kg:	45
Protection:	IP55
Cooling:	IC41
Insu.class:	F
Starting method:	DOL
Efficiency	85,7%
cos (fi)	0,82

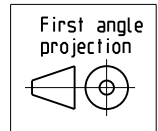
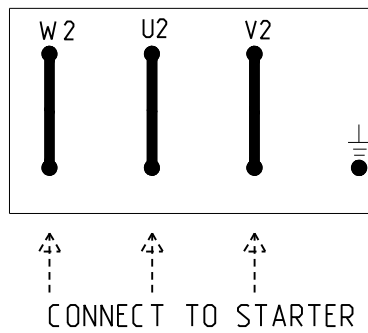

Only to the extent expressly agreed by us this document may constitute a contractual obligation on our part.

This document and its contents are our exclusive property and must not be copied, reproduced, transmitted or communicated to any other party or used for purposes not expressly permitted by us.

A	Tabell rev.	2005.01.21 LN	
	Original	2004.05.18 LN	JS
Rev.	Revision	Revised (Date/Sign)	Appr.

Drawing Type-No.

X-MOT-782

Rev.

A



IMO AB
Stockholm
Sweden

SPARE PARTS LIST

ACG 070K7 NVBP

Drawing Type-No.

S-ACG-225

Sheet 1 of 3

Only to the extent expressly agreed by us this document may constitute a contractual obligation on our part.

This document and its contents are our exclusive property and must not be copied, reproduced, transmitted or communicated to any other party or used for purposes not expressly permitted by us.

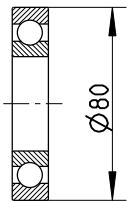
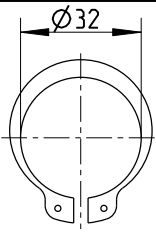
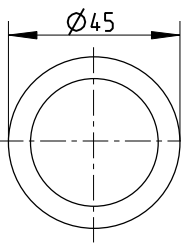
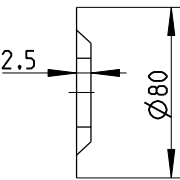
Item	Art.no	Name	Sketch	Qty	Pos.no	Remarks
1	191247	MINOR KIT G053				Pos.no: 122, 124 124A, 359A, 462A, 506 509, 537A 556, 602 605
		BALL BEARING PUMP		1	122	Steel
		RETAINING RING		1	124	Steel
		SUPPORT RING		1	124A	Steel
		NILOS RING		1	359A	Steel

Original	03.01.21 LN	Drawing Type-No.	Rev.
Rev.	Revision	Revised (Date/Sign) Appr.	S-ACG-225



IMO AB
Stockholm
Sweden

SPARE PARTS LIST

ACG 070K7 NVBP

Drawing Type-No.

S-ACG-225

Sheet 2 of 3

Only to the extent expressly agreed by us this document may constitute a contractual obligation on our part.

This document and its contents are our exclusive property and must not be copied, reproduced, transmitted or communicated to any other party or used for purposes not expressly permitted by us.

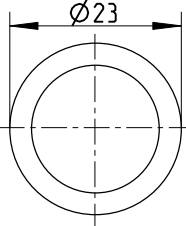
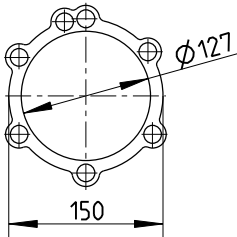
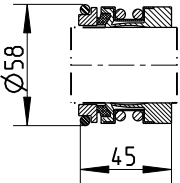
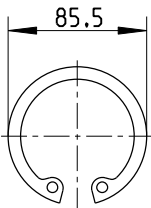
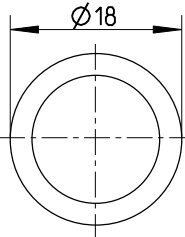
Item	Art.no	Name	Sketch	Qty	Pos.no	Remarks
		WASHER		2	462A	Aluminium
		GASKET		1	506	KlingerSil
		SHAFT SEAL	Art.no 190340 	1	509	G050
		RETAINING RING		1	514	Steel
		WASHER		2	537A	Aluminium

Original	03.01.21 LN	Drawing Type-No.	Rev.
Rev.	Revision	Revised (Date/Sign) Appr.	S-ACG-225



IMO AB
Stockholm
Sweden

SPARE PARTS LIST

ACG 070K7 NVBP

Drawing Type-No.

S-ACG-225

Sheet 3 of 3

Only to the extent expressly agreed by us this document may constitute a contractual obligation on our part.

This document and its contents are our exclusive property and must not be copied, reproduced, transmitted or communicated to any other party or used for purposes not expressly permitted by us.

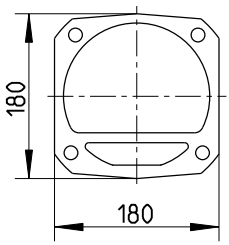
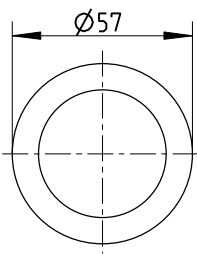
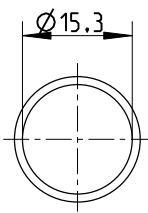
Item	Art.no	Name	Sketch	Qty	Pos.no	Remarks
		GASKET		1	556	KlingerSil
		WASHER		1	602	Aluminium
		O-RING		1	605	Fluor rubber

Original	03.01.21 LN	Drawing Type-No.	Rev.
Rev.	Revision	Revised (Date/Sign) Appr.	S-ACG-225

